

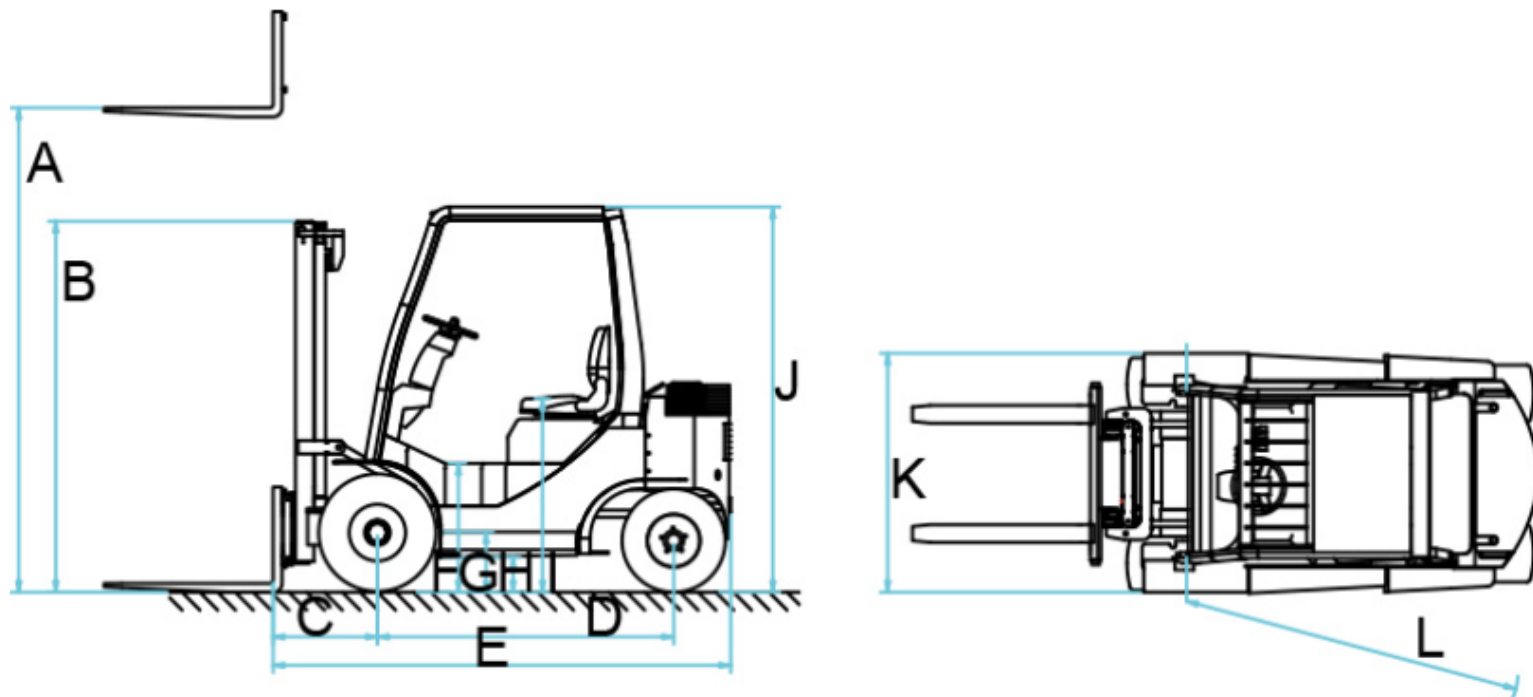

CHARIOT TIGER XL E ZERO EMISSION PRINS.



Model TIGER	XL-E	XXL-E	Model TIGER	XL-E	XXL-E
Type	1.0	1.0	Type	1.0	1.0
Capacité de charge	1000	1000	Tires profil A	295-50x15	295-50x15
Poid sans batterie	1665	1665	Avant profil B	27x12-15	27x12-15
Poids de la batterie	ca. 875 environ	ca. 875 environ	Pneus arrière	24-13x12	24-13x12
Poids sans batterie li-ion	1785	1785	# pneus avant	2 (seul) 4 (double)	4 (double)
Poids de la batterie li-ion	ca. 440 environ	ca. 440 environ	A mm	3200	3200
Centre de gravité	500	500	B mm	2600	2600
Angle avant/arrière	8°/9°	8°/9°	C mm	450	450
Plaque des branches	FEM 2b	FEM 2b	D mm	1750	1750
Transmission	automatique	automatique	E mm	2500	2500
Carburant	électrique	électrique	F mm	750	750
Moteur	Cesab	Cesab	G mm	380	380
Type de moteur	S2	S2	H mm	240	260
Puissance	6	6	I mm	1200	1200
Vitesse	18	18	J mm	2240	2240
			K mm	1340 2020	2020
			L mm	2400	2000

